



**FITTING INSTRUCTIONS FOR LP0259SI LICENCE PLATE BRACKET**  
**HONDA MONKEY 2018**



**THIS KIT CONTAINS THE ITEMS PICTURED AND LABELLED BELOW.**  
**DO NOT PROCEED UNTIL YOU ARE SURE ALL PARTS ARE PRESENT.**

Please note that the way the kit is packed does not necessarily represent the way of mounting to the bike.

THE PARTS SHOWN MAY BE REPRESENTATIVE ONLY (FOR CLARITY OF INSTRUCTIONS ONLY).

Please note that in cases where kits are packed with rubber washers holding the components onto the bolt – *the rubber washers should be thrown away!*

Digital copies of these instructions are available to download from [www.rg-racing.com](http://www.rg-racing.com)

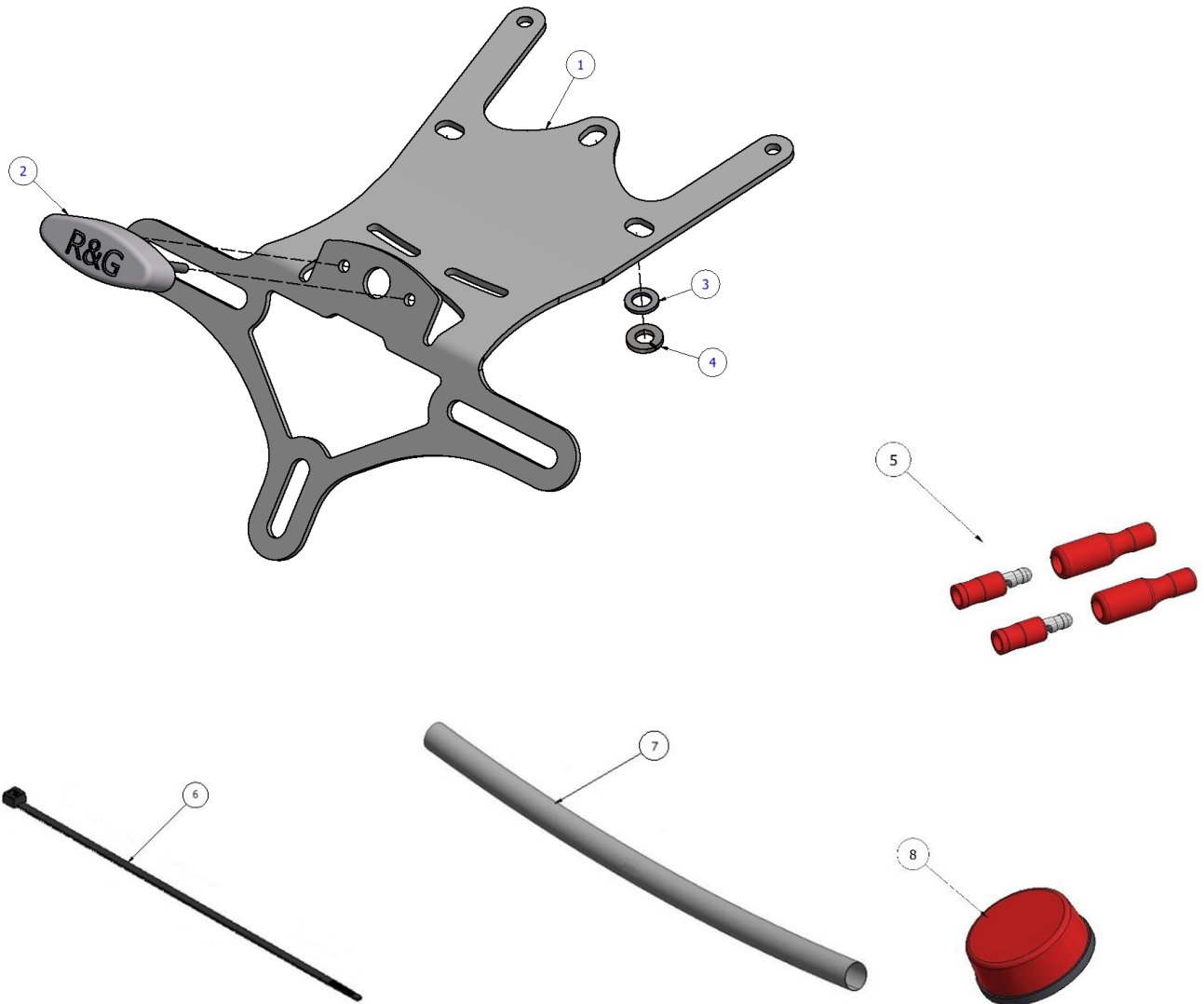

### **LEGEND**

- ITEM 1 = LICENCE PLATE BRACKET (TB0259). (x1)  
 ITEM 2 = LICENCE PLATE ILLUMINATOR ASSEMBLY (LA0002). (x1)  
 ITEM 3 = M6 WASHER (x3)  
 ITEM 4 = M6 SPRING WASHER. (x3)  
 ITEM 5 = CON0004 (x1)  
 ITEM 6 = SMALL CABLE TIES (x1)  
 ITEM 7 = 180mm LONG HEAT SHRINK. (x1)  
 ITEM 8 = REFLECTOR (x1)

R&G

Unit 1, Shelley's Lane, East Worldham, Alton, Hampshire, GU34 3AQ  
 Tel: +44 (0)1420 89007 Fax: +44 (0)1420 87301 [www.rg-racing.com](http://www.rg-racing.com) Email: [info@rg-racing.com](mailto:info@rg-racing.com)



**TOOLS REQUIRED**

- 10mm socket.
- Philips screwdriver

**MAXIMUM TORQUE SETTINGS**

- M4 BOLT = 8Nm
- M5 BOLT = 12Nm
- M6 BOLT = 15Nm
- M8 BOLT = 20Nm
- M10 BOLT = 40Nm

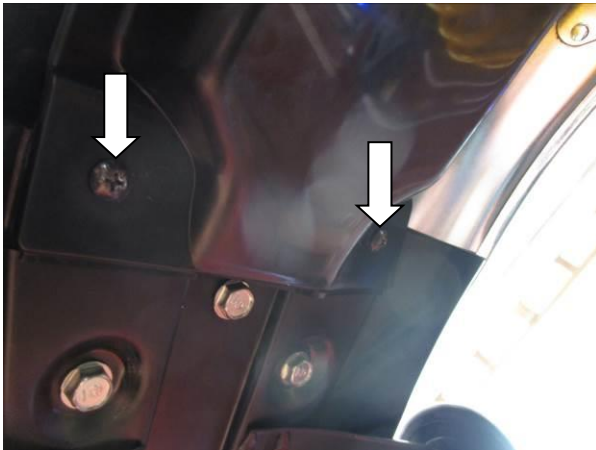

Picture 1



Picture 2

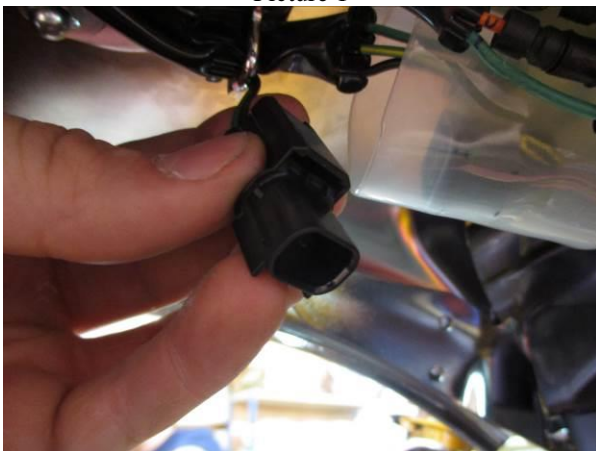

Picture 3



Picture 4

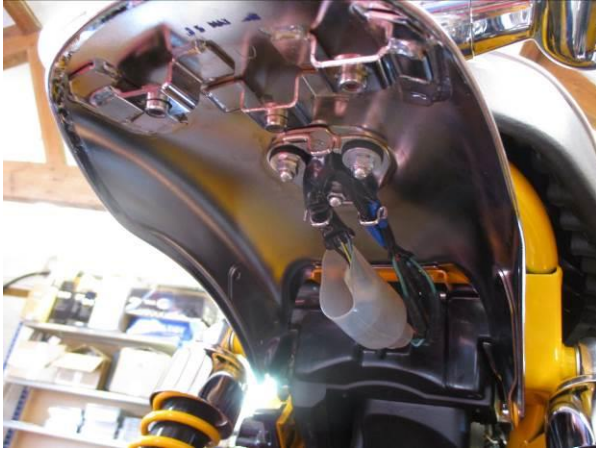

Picture 5

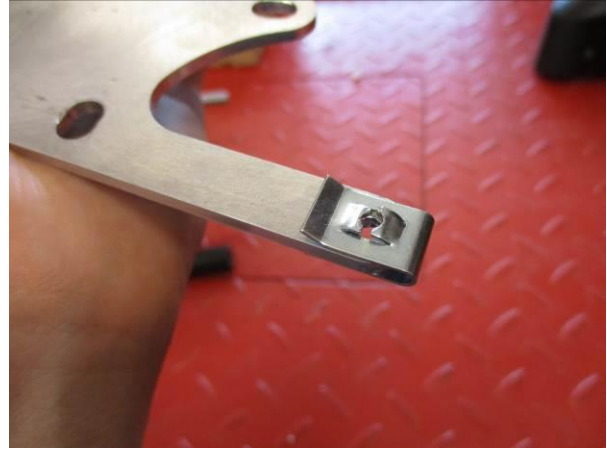

Picture 6



Picture 7

### **FITTING INSTRUCTIONS**

- Remove the two screws under the rear fender, shown in Picture 1.
- Remove the two plastic push rivets, to release the plastic cover (Picture 2).
- Disconnect the licence plate illuminator connector (Picture 3).
- While supporting the plastic fender, undo the three bolts shown in Picture 4 and remove the fender from the bike (Picture 5).
- Remove the two Panel U Clips from the plastic fender and fit them to the two tabs on the tail tidy (Picture 6).
- Fit the licence plate illuminator assembly to the tail tidy using the bolts, washers and nuts provided, please note you will have to fit the light shroud and use a small amount of adhesive to hold it in position.
- To connect the wiring to the licence plate illuminator, the wiring needs to be “cut & shut”. To do this, cut the connector and at least 50mm of wiring off the original licence plate illuminator and fit the bullet connectors that are supplied with the LA0002 to the exposed end of both wires. Connect these to the LA0002 bullet connectors and then re-connect the connector block to the black connector on the OEM loom (if illumination fails, reverse the bullet connectors).
- Fit the tail tidy to the bike (Picture 7), using the three original bolts, and washers (ITEM 3 and ITEM 4).
- Re-fit the plastic cover using the plastic pop-rivets, and two screws.
- Refit the licence plate (it may require drilling).
- Please check the operation of all lights before riding the motorcycle.

R&G

Unit 1, Shelley's Lane, East Worldham, Alton, Hampshire, GU34 3AQ

Tel: +44 (0)1420 89007 Fax: +44 (0)1420 87301 [www.rg-racing.com](http://www.rg-racing.com) Email: [info@rg-racing.com](mailto:info@rg-racing.com)



**IMPORTANT: IF FITTING A FULL-SIZE LICENCE PLATE AND PLACING IT FAR DOWN ON THE LICENCE PLATE HANGER, THERE IS A SMALL CHANCE OF THE LICENCE PLATE HITTING THE BACK WHEEL UNDER HEAVY LOAD AND OVER LARGE BUMPS IN THE ROAD. IT IS YOUR RESPONSIBILITY TO CHECK FOR THIS POSSIBILITY AND TAKE AVOIDING ACTION. FAILURE TO CHECK THIS COULD RESULT IN SERIOUS INJURY.**

- Depending on local laws, attach enclosed reflector (ITEM 8) in an appropriate location.

ISSUE 1 26/09/2018 (LF)

#### CONSUMER NOTICE

The catalogue description and any exhibition of samples are only broad indications of the Products and R&G may make design changes which do not diminish their performance or visual appeal and supplying them in such state shall conform to the order. The Buyer acknowledges no representation or warranty (other than as to title) has been given or will apply to the Products other than those in R&G's order or confirmation and the Buyer confirms it has chosen the Products as being of merchantable quality and suitable for its particular purposes. Where R&G fits the Products or undertakes other services it shall exercise reasonable skill and care and rectify any fault free of charge unless the workmanship has been disturbed. The Buyer is responsible for ensuring that the warranty on the motorcycle is not affected by the fitting of the Products. On return of any defective Products R&G shall at its option either supply a replacement or refund the purchase money but shall not be liable if the Products have been modified or used or maintained otherwise than in accordance with R&G's or manufacturer's instructions and good engineering practice or if the defect arises from accident or neglect. Other than identified above and subject to R&G not limiting its liability for causing death and personal injury, it shall not be liable for indirect or consequential loss and otherwise its liability shall be limited to the amounts paid by the Buyer for the Products or the fitting or service concerned. These terms do not affect the Buyer's statutory rights.

#### R&G RETURNS POLICY (NON-FAULTY GOODS)

Returns must be pre-authorised (if not pre-authorised the return will be rejected). Goods may only be returned direct to us if they were purchased direct from us (customer must prove if necessary). Otherwise to be returned to original vendor. Goods must be in re-sellable condition, in the opinion of R&G. All returns are subject to a 25% restocking and handling fee (25% of the gross value exc. P&P – at the prevailing price at time of purchase). The customer must pay any and all carriage charges. No returns of discontinued products, unless within 14 days of purchase. This policy does not affect your statutory rights and does not refer to faulty goods.

R&G

Unit 1, Shelley's Lane, East Worldham, Alton, Hampshire, GU34 3AQ

Tel: +44 (0)1420 89007 Fax: +44 (0)1420 87301 [www.rg-racing.com](http://www.rg-racing.com) Email: [info@rg-racing.com](mailto:info@rg-racing.com)



**NOTICE DE MONTAGE POUR LP0259SI SUPPORT DE PLAQUE**  
**HONDA MONKEY 2018**



**Le kit contient les articles exposés ci-dessous, vérifier que toutes les pièces soient présentes avant de procéder au montage.**

**La façon dont le kit est emballé ne correspond pas forcément à la façon de monter les pièces sur la moto.**

**LES PARTIES PRESENTEES PEUVENT ETRE UNIQUEMENT REPRESENTATIVES (POUR LA CLARTÉ DES INSTRUCTIONS UNIQUEMENT).**

**Notez que si les kits sont emballés avec des rondelles en caoutchouc servant à tenir les composants, *ces rondelles doivent être jetées !***

**Notice disponible au téléchargement sur [www.rg-racing.com](http://www.rg-racing.com)**

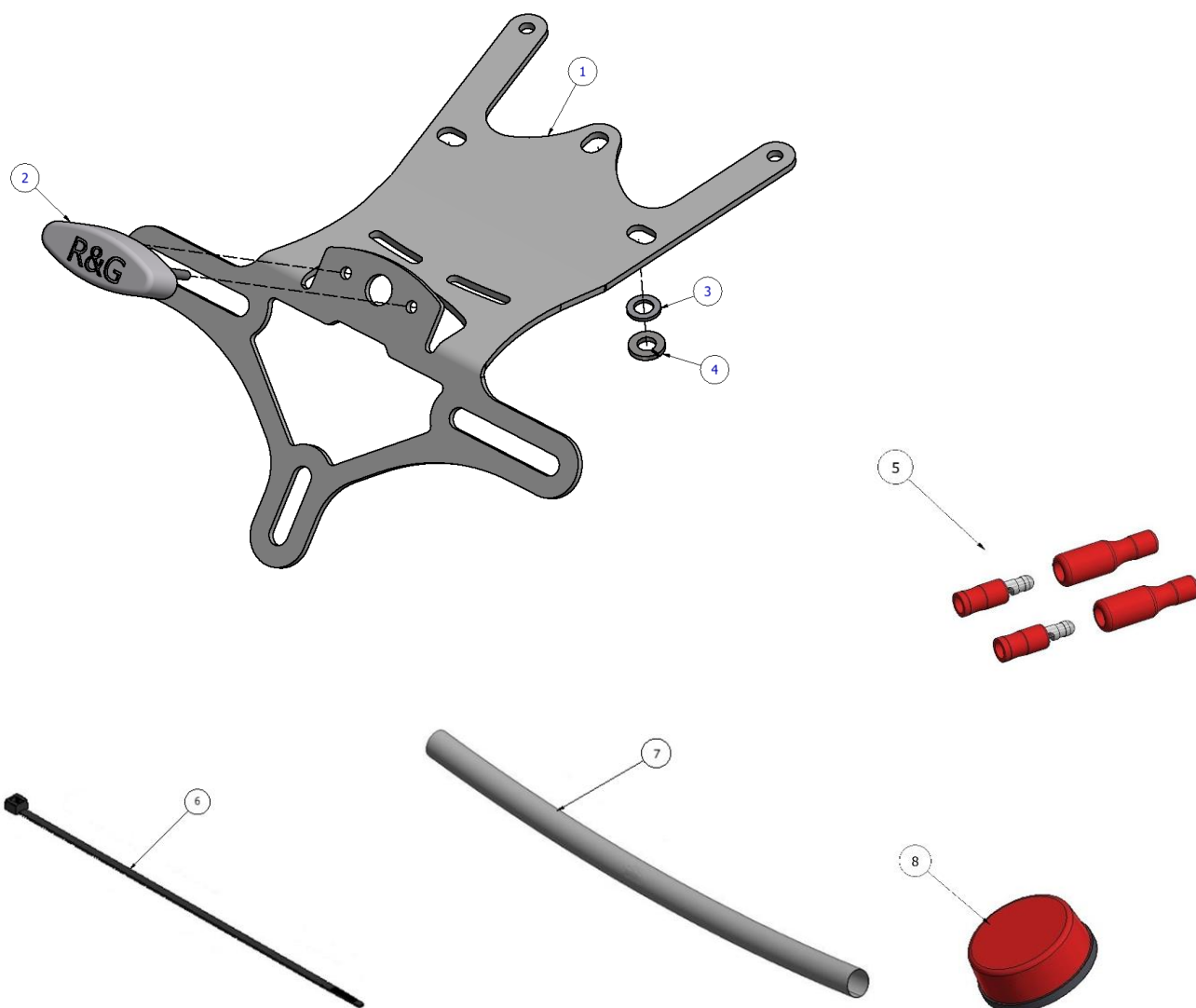

### LÉGENDE

- ARTICLE 1 = SUPPORT DE PLAQUE (TB0259) (x1)  
 ARTICLE 2 = ASSEMBLAGE DE FEU DE PLAQUE (LA0002). (x1)  
 ARTICLE 3 = M6 RONDELLE (x3)  
 ARTICLE 4 = M6 RONDELLE DE RESSORT (x3)  
 ARTICLE 5 = CON0004 (x1)  
 ARTICLE 6 = COLLIERS DE SERRAGE (x1)  
 ARTICLE 7 = 180mm LONGUEUR DE MANCHON THERMO RÉTRACTABLE (x1)  
 ARTICLE 8 = RÉFLECTEUR (x1)

R&G



**OUTILS REQUIS**

- Clé 10mm.
- Tournevis cruciforme

**VALEURS DE SERRAGE**

- M4 BOULON = 8Nm
- M5 BOULON = 12Nm
- M6 BOULON = 15Nm
- M8 BOULON = 20Nm
- M10 BOULON = 40Nm

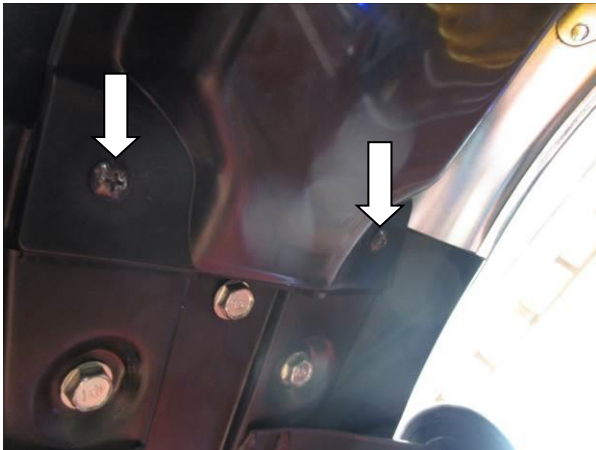

Photo 1



Photo 2



Photo 3



Photo 4





Photo 5

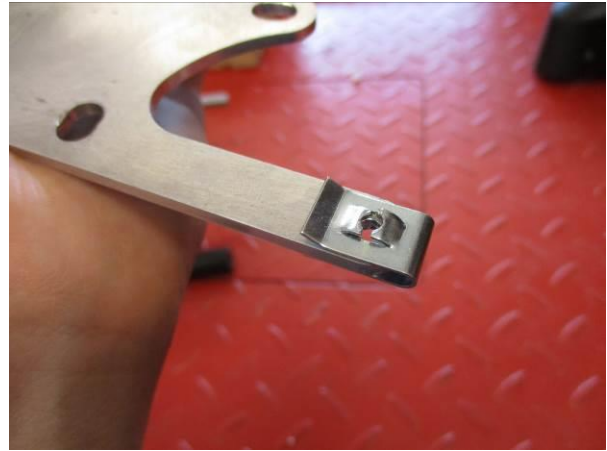

Photo 6



Photo 7

### **NOTICE DE MONTAGE**

- Enlever les 2 vis sous le garde-boue arrière, voir photo 1.
- Enlever les 2 rivets, pour libérer le cache plastique (photo 2).
- Déconnecter le connecteur de feu de plaque (photo 3).
- Tout en supportant le garde-boue, enlever les 3 boulons indiqués sur la photo 4 puis enlever le garde-boue de la moto (photo 5).
- Enlever les 2 clips U de carénage du garde-boue puis montez les sur les 2 onglets du support de plaque (photo 6).
- Monter l'assemblage de feu de plaque en utilisant les boulons, rondelles et écrous fournis, notez que vous devrez monter le linceul de feu en utilisant un peu d'adhésif pour fixer la position.
- Pour connecter le fil au feu de plaque, le fil devra être "coupé et fermé". Pour cela, couper le connecteur à minimum 50mm du feu de plaque puis monter les connecteurs fournis avec le LA0002 sur l'extrémité des 2 fils.
- Connectez-les aux connecteurs LA0002 puis reconnectez le bloc de connecteur au connecteur noir sur le faisceau d'origine (Si l'éclairage échoue, tournez les connecteurs).
- Monter le support de plaque sur la moto (photo 7), en utilisant les 3 boulons d'origine, et rondelles (article 3 et article 4).
- Remonter le cache plastique en utilisant les rivets plastique, et 2 vis.
- Remonter la plaque d'immatriculation (peut nécessiter un perçage).
- Tester l'ensemble des feux avant de prendre la route.

R&G

Unit 1, Shelley's Lane, East Worldham, Alton, Hampshire, GU34 3AQ

Tel: +44 (0)1420 89007 Fax: +44 (0)1420 87301 [www.rg-racing.com](http://www.rg-racing.com) Email: [info@rg-racing.com](mailto:info@rg-racing.com)



- **IMPORTANT : Si vous installez une grosse plaque, il y a un risque que la plaque entre en contact avec la roue arrière en cas de choc sur la route (bosse, grosse charge etc..). Il est de votre responsabilité de vérifier que cela ne puisse pas se produire. Ne pas effectuer ces vérifications peut entraîner des dommages ainsi que des blessures graves pour le pilote.**
- Selon les lois locales, attacher le réflecteur rouge (article 14) à l'endroit approprié.

ISSUE 1 26/09/2018 (LF)

#### CONSUMER NOTICE

The catalogue description and any exhibition of samples are only broad indications of the Products and R&G may make design changes which do not diminish their performance or visual appeal and supplying them in such state shall conform to the order. The Buyer acknowledges no representation or warranty (other than as to title) has been given or will apply to the Products other than those in R&G's order or confirmation and the Buyer confirms it has chosen the Products as being of merchantable quality and suitable for its particular purposes. Where R&G fits the Products or undertakes other services it shall exercise reasonable skill and care and rectify any fault free of charge unless the workmanship has been disturbed. The Buyer is responsible for ensuring that the warranty on the motorcycle is not affected by the fitting of the Products. On return of any defective Products R&G shall at its option either supply a replacement or refund the purchase money but shall not be liable if the Products have been modified or used or maintained otherwise than in accordance with R&G's or manufacturer's instructions and good engineering practice or if the defect arises from accident or neglect. Other than identified above and subject to R&G not limiting its liability for causing death and personal injury, it shall not be liable for indirect or consequential loss and otherwise its liability shall be limited to the amounts paid by the Buyer for the Products or the fitting or service concerned. These terms do not affect the Buyer's statutory rights.

#### R&G RETURNS POLICY (NON-FAULTY GOODS)

Returns must be pre-authorized (if not pre-authorized the return will be rejected). Goods may only be returned direct to us if they were purchased direct from us (customer must prove if necessary). Otherwise to be returned to original vendor. Goods must be in re-sellable condition, in the opinion of R&G. All returns are subject to a 25% restocking and handling fee (25% of the gross value exc. P&P – at the prevailing price at time of purchase). The customer must pay any and all carriage charges. No returns of discontinued products, unless within 14 days of purchase. This policy does not affect your statutory rights and does not refer to faulty goods.

R&G

Unit 1, Shelley's Lane, East Worldham, Alton, Hampshire, GU34 3AQ

Tel: +44 (0)1420 89007 Fax: +44 (0)1420 87301 [www.rg-racing.com](http://www.rg-racing.com) Email: [info@rg-racing.com](mailto:info@rg-racing.com)



**MONTAGEANLEITUNG FÜR LP0259SI KENNZEICHENHALTER**  
**HONDA MONKEY 2018**



**ALLE KIT-TEILE SIND UNTEN ABGEBILDET UND GEKENNZEICHNET. BEVOR SIE MIT DER MONTAGE BEGINNEN, ÜBERPRÜFEN SIE, DASS ALLE TEILE VORHANDEN SIND.**

**Hinweis: Die Verpackung der Teile stellt nicht die Reihenfolge der Montage dar.**

DIE UNTEN ABGEBILDETEN TEILE DIENEN LEDIGLICH ZUR ERKLÄRUNG

**Hinweis für Kits mit Plastikunterlegscheiben an den Schrauben – Diese Plastikunterlegscheiben werden nicht für den Einbau benötigt!**

**Eine digitale Version dieser Montageanleitung kann auf folgender Seite heruntergeladen werden:**  
[www.rg-racing.com](http://www.rg-racing.com)

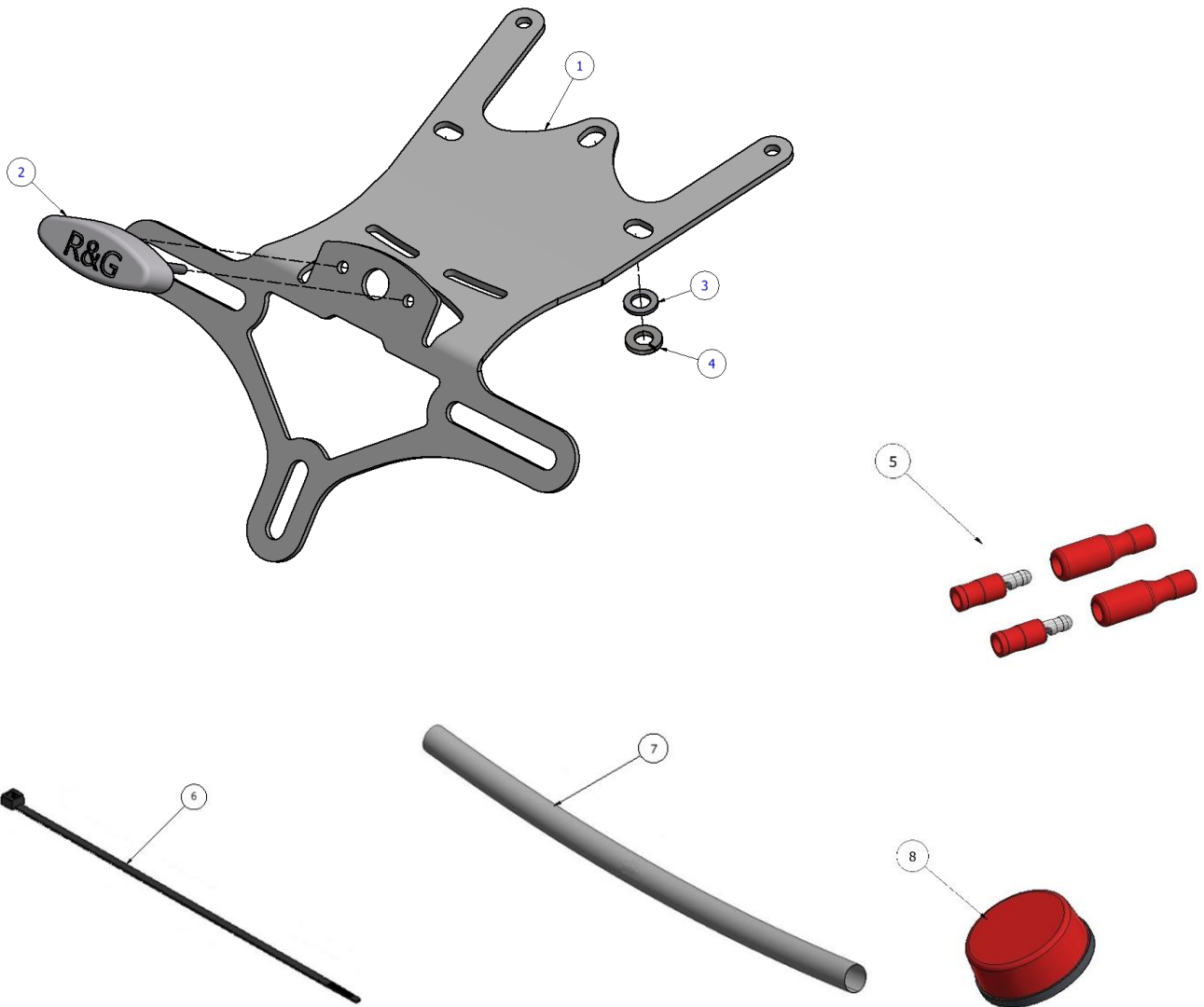

### **LIEFERUMFANG**

- ARTIKEL 1 = KENNZEICHENHALTER (TB0259) (x1)
- ARTIKEL 2 = KENNZEICHENBELEUCHTUNG (LA0002) (x1)
- ARTIKEL 3 = M6 UNTERLEGSSCHEIBE (x3)
- ARTIKEL 4 = M6 FEDERRING (x3)
- ARTIKEL 5 = CON0004 (x1)
- ARTIKEL 6 = KLEINE KABELBINDER (x1)
- ARTIKEL 7 = 180mm SCHRUMPFSCHLAUCH (x1)
- ARTIKEL 8 = RÜCKSTRAHLER (x1)

R&G

Unit 1, Shelley's Lane, East Worldham, Alton, Hampshire, GU34 3AQ  
 Tel: +44 (0)1420 89007 Fax: +44 (0)1420 87301 [www.rg-racing.com](http://www.rg-racing.com) Email: [info@rg-racing.com](mailto:info@rg-racing.com)



**SIE BENÖTIGEN FOLGENDES WERKZEUG**

- 10mm Steckschlüsselsatz
- Kreuzschlitzschraubendreher

**MAX. ANZUGSDREHMOMENTE:**

M4 SCHRAUBE = 8 NM  
M5 SCHRAUBE = 12NM  
M6 SCHRAUBE = 15NM  
M8 SCHRAUBE = 20NM  
M10 SCHRAUBE = 40NM



Abbildung 1



Abbildung 2

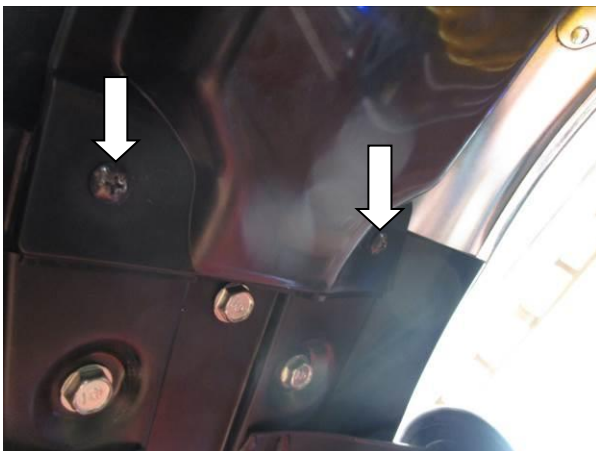

Abbildung 3



Abbildung 4

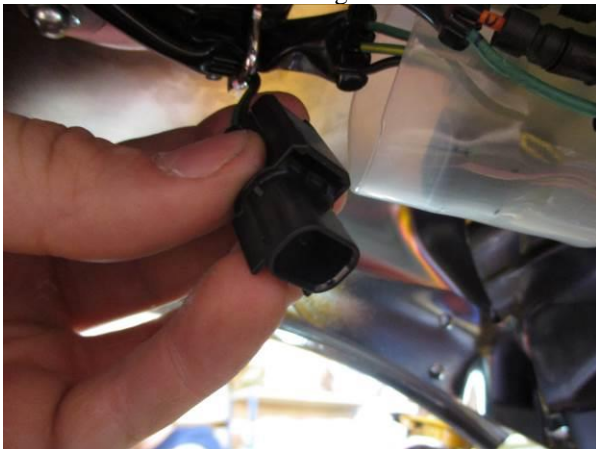

Abbildung 5

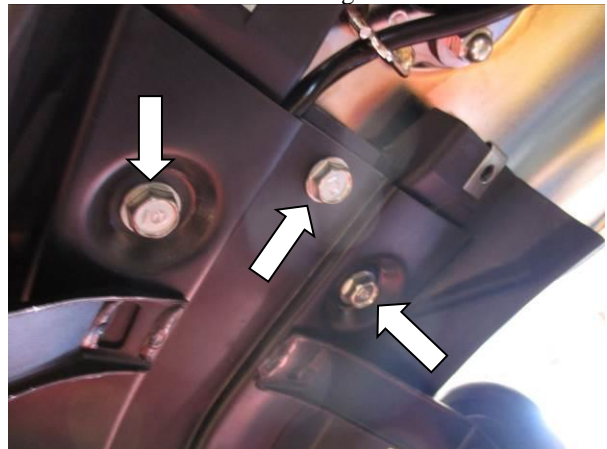

Abbildung 6



Abbildung 7

### **MONTAGEANLEITUNG**

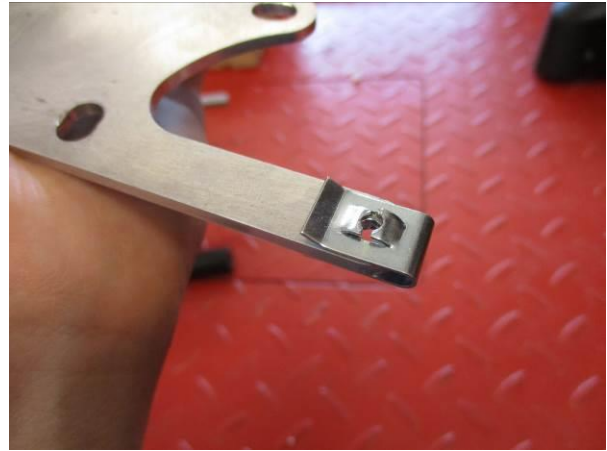
- Entfernen Sie die zwei Schrauben unter dem hinteren Schutzblech – siehe Abbildung 1.
- Entfernen Sie die zwei Plastiknieten, um die Plastikabdeckung zu lösen (Abbildung 2).
- Trennen Sie den Steckverbinder für die Kennzeichenbeleuchtung (Abbildung 3).
- Während Sie das Kunststoff-Schutzblech stützen, lösen Sie die drei Schrauben, die in Abbildung 4 abgebildet sind und entfernen Sie das Schutzblech vom Motorrad (Abbildung 5).
- Entfernen Sie die zwei U-Clips vom Kunststoff-Schutzblech und montieren Sie sie an den zwei Laschen am Kennzeichenhalter (Abbildung 6).
- Die Kennzeichenbeleuchtung-Einheit am Kennzeichenhalter mit den Schrauben, Muttern und Unterlegscheiben vom Kit befestigen. Hinweis: etwas Sekundenkleber wird benötigt, um die Lichtabdeckung in Position zu befestigen.
- Um die Kabel mit der Kennzeichenbeleuchtung verbinden zu können, muss die original Verkabelung für die Kennzeichenbeleuchtung abgetrennt und abisoliert werden. Den original Steckverbinder mit mindestens 50 mm Kabel abschneiden und die Kabelverbinder, die mit der LA0002 Kennzeichenbeleuchtung mitgeliefert werden, an den offenen Enden der zwei Kabel anbringen. Verbinden Sie sie mit der LA0002 Kennzeichenbeleuchtung, dann verbinden Sie die Anschlussleiste mit dem schwarzen Verbinder vom original Kabelbaum (falls die Beleuchtung nicht funktionieren sollte, tauschen Sie die Kabel untereinander).
- Montieren Sie den Kennzeichenhalter am Motorrad (Abbildung 7) mit den drei original Schrauben und Unterlegscheiben (Artikel 3 und 4).

R&G

Unit 1, Shelley's Lane, East Worldham, Alton, Hampshire, GU34 3AQ

Tel: +44 (0)1420 89007 Fax: +44 (0)1420 87301 [www.rg-racing.com](http://www.rg-racing.com) Email: [info@rg-racing.com](mailto:info@rg-racing.com)



- Montieren Sie die Kunststoffabdeckung wieder mit den Plastiknieten und den zwei Schrauben.
- Montieren Sie das amtliche Kennzeichen (Bohrungen im Kennzeichen evtl. notwendig).
- Überprüfen Sie die Funktion der Beleuchtung (Blinker und Kennzeichenhalterbeleuchtung) nochmal vor Gebrauch des Fahrzeuges.

**WICHTIG: WENN EIN GROSSES KENNZEICHEN ZU WEIT NACH UNTEN MONTIERT WIRD, BESTEHT BEI SCHWEREM LAST ODER DURCH GROSSE BODENWELLEN EIN GERINGES RISIKO, DASS DAS KENNZEICHEN AN DAS HINTERRAD STOSSEN KANN. ES LIEGT IN IHRER VERANTWORTUNG DIES ZU ÜBERPRÜFEN UND, WENN NOTWENDIG, VORZUBEUGENDE MASSNAHMEN ZU ERGREIFEN. DIE NICHTBEACHTUNG DIESES SICHERHEITSHINWEIS KANN ZU SCHWEREN VERLETZUNGEN FÜHREN.**

- Entsprechend der gesetzlichen Vorschriften, den mitgelieferten Rückstrahler (Artikel 8) anbringen.

AUSGABE 1 26/09/2018 (LF)

#### CONSUMER NOTICE

The catalogue description and any exhibition of samples are only broad indications of the Products and R&G may make design changes which do not diminish their performance or visual appeal and supplying them in such state shall conform to the order. The Buyer acknowledges no representation or warranty (other than as to title) has been given or will apply to the Products other than those in R&G's order or confirmation and the Buyer confirms it has chosen the Products as being of merchantable quality and suitable for its particular purposes. Where R&G fits the Products or undertakes other services it shall exercise reasonable skill and care and rectify any fault free of charge unless the workmanship has been disturbed. The Buyer is responsible for ensuring that the warranty on the motorcycle is not affected by the fitting of the Products. On return of any defective Products R&G shall at its option either supply a replacement or refund the purchase money but shall not be liable if the Products have been modified or used or maintained otherwise than in accordance with R&G's or manufacturer's instructions and good engineering practice or if the defect arises from accident or neglect. Other than identified above and subject to R&G not limiting its liability for causing death and personal injury, it shall not be liable for indirect or consequential loss and otherwise its liability shall be limited to the amounts paid by the Buyer for the Products or the fitting or service concerned. These terms do not affect the Buyer's statutory rights.

#### R&G RETURNS POLICY (NON-FAULTY GOODS)

Returns must be pre-authorized (if not pre-authorized the return will be rejected). Goods may only be returned direct to us if they were purchased direct from us (customer must prove if necessary). Otherwise to be returned to original vendor. Goods must be in re-sellable condition, in the opinion of R&G. All returns are subject to a 25% restocking and handling fee (25% of the gross value exc. P&P – at the prevailing price at time of purchase). The customer must pay any and all carriage charges. No returns of discontinued products, unless within 14 days of purchase. This policy does not affect your statutory rights and does not refer to faulty goods.

R&G

Unit 1, Shelley's Lane, East Worldham, Alton, Hampshire, GU34 3AQ

Tel: +44 (0)1420 89007 Fax: +44 (0)1420 87301 [www.rg-racing.com](http://www.rg-racing.com) Email: [info@rg-racing.com](mailto:info@rg-racing.com)